

# A Tuneable liquid lens driven by a micro coil actuator and a ferrofluidic plug inside a micro channel structure

Thanin Schultheis

Hanover Center of Optical Technology,

Institute of Measurement and Automatic Control,

Leibniz Universität Hannover

Nienburger Straße. 17, 30167 Hanover, Germany

E-Mail: thanin.schultheis@imr.uni-hannover.de

## Abstract

To combine optics and fluidics becomes more and more popular and opens interesting fields of research. Though some efforts have already been made to create tuneable liquid lens systems this research work follows a new approach. The main difference can be found in the actuating mechanism, which is a contactless conversion from an electromagnetic driving force into a volume displacement respectively a pressure increase. Here a ferrofluidic plug takes the role of a piston which is interspersed with an electromagnetic field. This ferrofluidic plug is located within a micro channel structure made out of Polymethyl metacrylate (PMMA) via a hot embossing process [1]. The electromagnetic field on the other hand is generated by a pair of micro coil actuators, which are controlled by a therefore designed hardware and software.

**Keywords:** focal length, ferrofluid, micro coil actuator, liquid lens, tuneable micro lens, optofluidic

## 1 INTRODUCTION

The optofluidic is a combination of optics and (micro) fluidics and aims on generating and modifying optical elements by using fluids in micro structures [2]. The aim within the topic of optofluidics can be very different like Armin Werber showed in his dissertation [3]. For example does the optofluidics not only imply tuneable lenses or lenses of a different kind but also systems which drives an optical element by using a fluidic mechanism like the tilting mirrors [3] (Figure 1, Figure 2) introduced in his work.

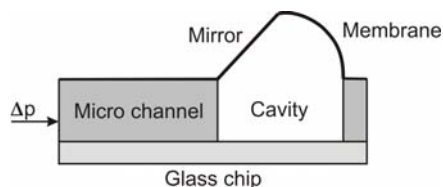

Figure 1: schematic of a tilting mirror ( $l = 1.3$  mm,  $w = 1$  mm) using a pressure difference transported into a cavity through a micro channel to tilt a micro mirror about a certain angle. The cavity is covered by a membrane.

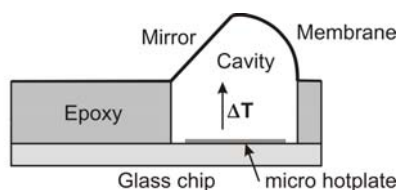

Figure 2: schematic of a tilting mirror ( $l = 1.3$  mm,  $w = 1$  mm) using a hotplate to heat up a fluid inside a cavity to tilt a micro mirror about a certain angle. The cavity is covered by a membrane.

Different research groups put effort in building tuneable systems with the possibility to change the focal length of a liquid lens [4; 5]. These concepts are presented in the second part of this article.

The aim of this research work, which is embedded in the special priority program (SPP) 1337 'Active micro optics' is to develop a tuneable micro lens system. The SPP is funded by the German Research Foundation (DFG). This system contains a pair of micro coil actuators, a magneto sensitive fluid – a ferrofluid – and a micro channel

structure. The ferrofluidic plug is located between the pair of actuators which are mounted vis-a-vis onto the substrate which is made out of Polymethyl methacrylate (PMMA), a mostly transparent thermoplastic with similar properties like common glass. A very thin layer ( $< 20$   $\mu\text{m}$ ) of PMMA is between the actuator and the ferrofluid to reduce the loss of the produced magnetic field strength which decreases with the distance (Biot-Savarts-Law). By applying a voltage to the coils a current through the coils caused by Ohm's law excites a magnetic field. This field again drives the ferrofluidic plug inside the channel. The movement of the ferrofluid again causes a volume displacement on a second, an optical liquid, for example water. The PMMA substrate provides an outlet drilling where the lens liquid exits. Since the volume displacement causes a pressure increase in the magnitude of a Laplace pressure the surface tension (or a membrane) can compensate the generated pressure and forces the liquid in a spherical shape which hence can be used as a refractive surface – the lens.

## 2 DIFFERENT CONCEPTS FOR TUNEABLE LIQUID LENSES

Different research groups already did successful approaches on tuneable liquid lenses. They all have in common that the lens itself is made out of a liquid and not made of a solid material like glass or a plastic material. The main difference exists in either the driving mechanism, how to form the lens surface or both.

The approach "varioptic" has chosen is based on the electrowetting effect [4]. An oil and a water based phase is put together inside a small sized cylindrical chamber with transparent bottom and top (Figure 3). On the side the liquids face an inclined boundary. By applying a voltage on this inclined boundary areas the contact angle of the liquid is changed. The change of the contact angle influences directly the curvature radius and therefore the focal length of the liquid lens. The possibility to tune the focal length is therefore given by just changing the voltage applied on the boundary of the liquid phase.

This system is produced and commercially available. The company varioptic sells these kinds of lens systems to be built in cell phone cameras for example.

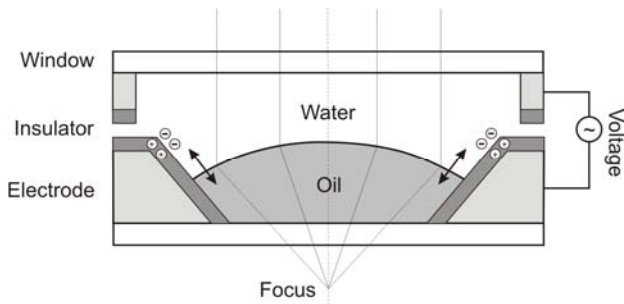

Figure 3: schematic of a tuneable lens using the electrowetting effect. With varying the applied voltage the contact angle on the inclined boundary is influenced. This is the working principle of commercially available tuneable micro lenses made by varioptic.

Another approach was made by [5]. A piezo electric transducer (a stack of multiple piezoelectric actuators) generates pressure onto a liquid filled chamber. This pressure is induced through a metal membrane which builds the top of the chamber with one liquid. A hole connects this chamber with another one containing a second liquid. These two liquids are immiscible and generate a liquid-liquid-phase interface at the level of the hole (Figure 4).

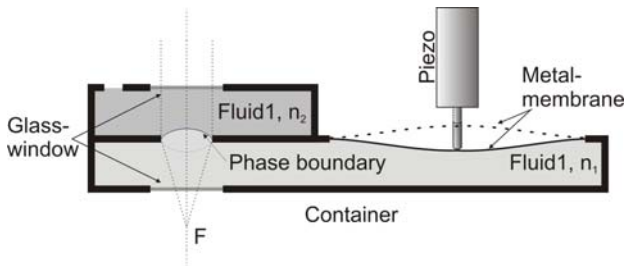

Figure 4: schematic of a tuneable lens using the piezoelectric and mechanical deformation effect combined with high frequency actuation. By applying a pressure generated by a stack of piezo actuators the a metal membrane is deformed and this deformation is transported to a immiscible liquid-liquid phase boundary to vary the focal length of a so produced liquid lens.

Since the deflection of the used piezo is small (in the range of  $10\ \mu\text{m}$ ) the metal membrane which is deformed by the piezo provides a much larger area as the liquid-liquid interface. That causes an amplification of the piezo's deflection.

The Japanese research group, who published this concept in the year 2009, measured a minimum response time of approximately 2 ms.

### 3 EXPERIMENT AND DESCRIPTION

As already mentioned, this research work is about the development of a tuneable liquid lens. The focal length shall be tuned with an electromagnetic mechanism which converts the resulting magnetic force of a B-field into a volume displacement respectively a pressure through a magnetic sensitive fluid.

The experimental setup realized like the way the sketch (Figure 5) shows gives the possibility to evaluate the optical properties of the liquid lens itself. Figure 6 shows a picture of the experimental setup in the laboratory.

The linear motor, a Zaber Nema NA08B16 and a suitable motor controller Zaber KT-MCA were used. Though the resolution of this stepper motor is approximately  $19\ \mu\text{m}$  per revolution it is quite difficult to adjust the position of the ferrofluidic plug that way that a sharp and clear picture is taken by the CCD element.

Elastic effects related to the viscosity of the used fluids make it even more difficult to adjust the focal length correctly.

Out of this reasons efforts are being made to comprise all the influencing effects, so that this difficulty can be minimized or in the optimum being ruled out.

FEM simulations and optical simulations are carried out to provide a good a priori estimation.

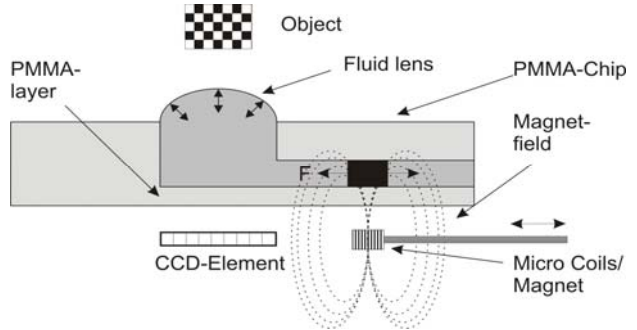

Figure 5: sketch of the experimental setup. The ferrofluid inside the micro channel follows the movement of a permanent magnet attached on a rod of a linear motor. Due to this volume so caused displacement the liquid lens is developed and can be used to focus an object on a CCD element.

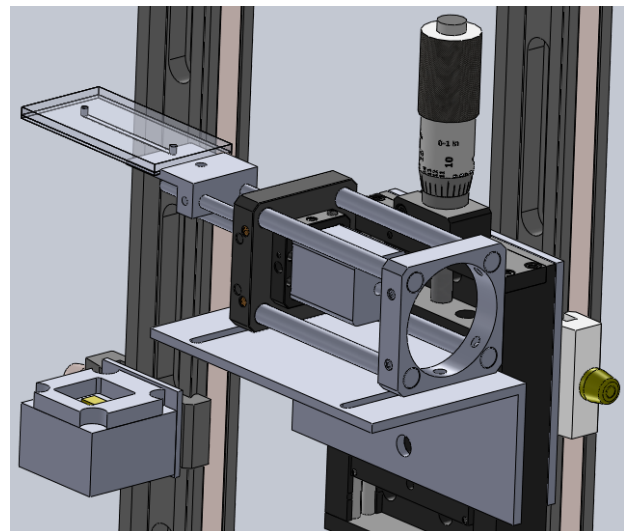

Figure 6: CAD model of the experimental setup according to sketch (Figure 5).

#### 3.1 Controlling hardware

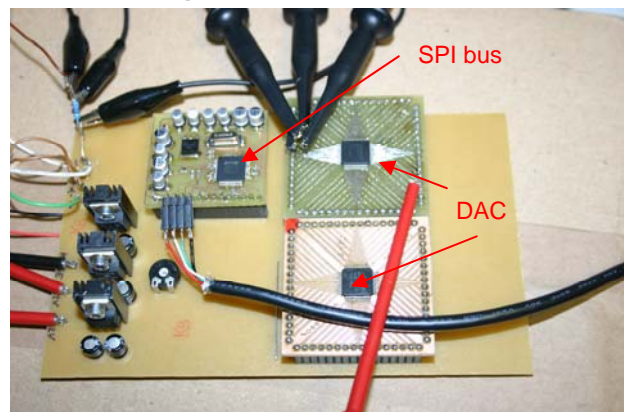

Figure 7: picture of the experimental setup according to sketch (Figure 5).

In preparation of the second stage of the experiments we have developed a controlling hardware for the micro coil actuators. This hardware mainly contains of a serial peripheral interface (SPI) bus which is controlled by a computer and again controls two digital analogue converters (DAC) (Figure 7). These DACs provide 32 channels with a resolution of 16 bit per channel. Because to each channel a single coil of the micro coil actuator is connected, a current is transmitted to the connected coil. This enables the user of the software to control each single coil or a set of coils of the micro actuator.

Additionally developed software for the hardware makes it easy to either control the coils individually or run a automated program.

#### 4 RESULTS

Though with the introduced experimental setup it is difficult

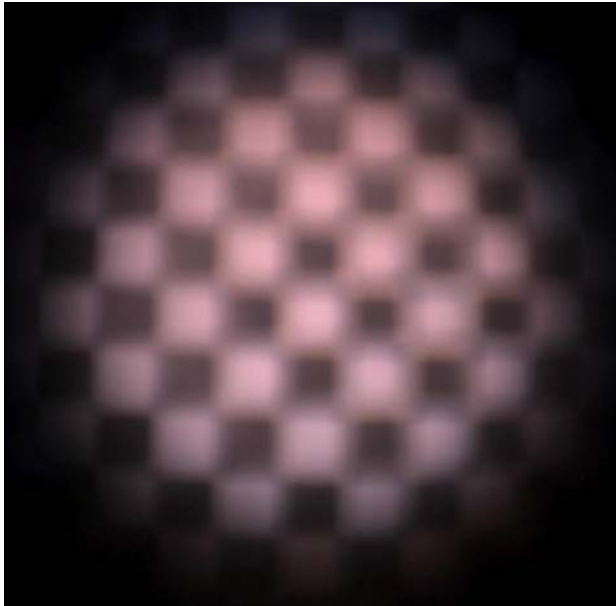

Figure 8: snapshot of an object (chessboard pattern) through a defocused liquid lens.

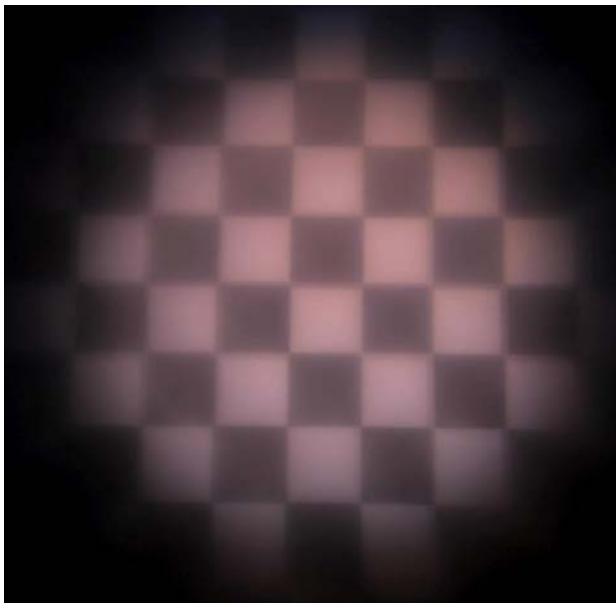

Figure 9: snapshot of chessboard pattern through a focused liquid lens.

to adjust, the correct focal length according to following equation, where  $f$  is the focal length,  $g$  the distance from the object to the lens and  $b$  the distance from the lens to the image plane respectively the CCD element:

$$\frac{1}{f} = \frac{1}{g} + \frac{1}{b}$$

Some good results could be retrieved from the experiments. As Figure 8 and 9 show focusing and defocusing with the introduced experimental setup is possible and leads to promising picture quality.

#### 5 SUMMARY AND PROSPECTIVE

The aim of this research work is a focusing liquid lens. So far the PMMA micro channel structures could be designed and manufactured as well as the micro coil actuators. Also most of the system integration – the combination of the fluid the PMMA structures and the attachment of the actuator chips onto the PMMA structure could be done successfully.

The main achievement is the volume displacement due to movement of the ferrofluidic plug inside the micro channel and therefore a displacement of the lens liquid itself. Focusing with the so developed liquid lens could be achieved.

The experiments have shown satisfying and promising results. These results have to be analysed concerning e.g. distortion.

FEM and optical simulations will be carried out to support the difficult adjustment process.

Additionally and consequently the next steps will be to implement the micro coil actuator and to replace the permanent magnet, so test on the electronic hardware, the coil controlling and the written software can be carried out.

#### 6 ACKNOWLEDGEMENT

The work described in this paper is funded by the German Research Foundation (DFG) within the Special Priority Program (SPP) 1337 'Active Microoptics'. Also the project partners from the Institute for Microtechnology and the Center of Smart Interfaces is thanked for good teamwork.

#### 7 REFERENCES

- [1] Worgull, Matthias, Hot Embossing: Theory and Technology of Microreplication, *Elsevier Science* (2008)
- [2] Whitesides, George M, The origins and the future of microfluidics, *nature* (2006).
- [3] Werber, Armin, Pneumatic microoptics, *Dissertation* (2007)
- [4] Saurei, Lisa, Peseux, Jerome, Laune, Frederic, Berge, Bruno Tunable liquid lens based on electrowetting technology: principle, properties and applications, *MicroOptics Conference Jena* (2004).
- [5] Oku, Hiromasa, Ishikawa, Masatoshi, A rapidly deformable liquid lens, *SPIE Optical Design & Engineering* (2009).